



**DIRECT-REPLACEMENT  
INSTALLATION AND SET-UP GUIDE**

**FOR HARLEY-DAVIDSON SOFTAIL, DYNA, AND TOURING 49MM GRIP ST  
ADJUSTABLE CARTRIDGE KITS**

---

# **GRIP ST CARTRIDGE KITS**

---

**APPLICABLE KITS:**

890-27-010

890-27-014

890-27-016

# CONTENTS

---

<b>INTRODUCTION</b>	<b>1</b>
<b>SAFETY INSTRUCTIONS</b>	<b>2</b>
<b>INSTALLATION GUIDELINES</b>	<b>3</b>
<b>FORK LEG REMOVAL</b>	<b>5</b>
<b>FORK DISASSEMBLY</b>	<b>6</b>
<b>FORK REASSEMBLY</b>	<b>8</b>
<b>FORK LEG INSTALLATION</b>	<b>14</b>
<b>FORK SET UP</b>	<b>15</b>
<b>MAINTENANCE</b>	<b>18</b>
<b>WARRANTY INFORMATION</b>	<b>19</b>
<b>CONTACT</b>	<b>20</b>

# INTRODUCTION

---

Thank you for choosing FOX direct-replacement cartridge kit for your motorcycle. FOX products are designed, tested, and manufactured by the finest professionals in the industry.

## WARNING

Please read the entire manual before attempting to install the cartridge kit on your motorcycle. When working on this product, always see the vehicle manufacturer's work shop manual for vehicle-specific procedures and important specifications. Be sure to clean the components you intend to modify to avoid contamination or damage during the installation process. If you have any questions call the FOX motorcycle shock service center at 831.740.4619.

To achieve the best performance and product longevity, periodic service and maintenance is required. Please refer to the MAINTENANCE section for more information.

Always use a calibrated torque wrench when tightening components. Failure to properly torque the parts can result in separation of the fork, which could cause loss of control resulting in a crash, bodily injury, or death!

Always use the appropriate lift equipment to ensure the vehicle is securely supported so that it will not tip. Placing body parts beneath an unstable vehicle may lead to serious injury or death.

It is advisable to have a professional motorcycle mechanic install the cartridge kit. In addition to these instructions, professional knowledge of disassembly/reassembly procedures and post installation checks must be known.

FOX recommends that you become thoroughly familiar with the handling characteristics of your modified vehicle before operating it under rigorous conditions. This will help to avoid potential loss of control events that could lead to serious injury or death. FOX further recommends that you use appropriate protective equipment at all times when operating your vehicle.

 **WARNING**

# SAFETY INSTRUCTIONS

---

- FOX direct-replacement cartridge kits are designed to fit and allow proper clearance with the stock components. If aftermarket suspension components are installed it is the customer's responsibility to ensure that interference between the FOX cartridge kit and other motorcycle fork components does not occur at any point in the fork stroke.
- FOX direct-replacement cartridge kits should always be installed as a set for maximum performance.
- Proper installation and service procedures are essential for the safe and reliable operation of the suspension components, requiring the experience and tools specially designed for this purpose. Installation and maintenance procedures for this product must be performed by a qualified service technician, to avoid potentially unsafe motorcycle handling characteristics, which may result in **SERIOUS INJURY** or **DEATH**.
- Adjusting your suspension will change the handling characteristics of your motorcycle. Under certain conditions, your adjusted motorcycle may be more susceptible to loss of control, which can result in **SERIOUS INJURY** or **DEATH**. Thoroughly familiarize yourself with the adjusted motorcycle handling characteristics before any rigorous vehicle operation. Wear protective body gear and a helmet when appropriate.
- Any attempt to misuse, misapply, modify, or tamper with any FOX product voids any warranty and may result in **SERIOUS INJURY** or **DEATH**.

 **WARNING**

# INSTALLATION GUIDELINES

---

- Always use a motorcycle floor jack for the installation of forks, and make certain that the raised motorcycle is securely attached to the lift to prevent the motorcycle from slipping, falling, or moving during the installation process.
- DO NOT install any FOX product without the necessary special tools, expertise and a motorcycle floor jack or you will subject yourself to the risk of **SERIOUS INJURY** or **DEATH**. Ensure that the motorcycle is: (1) on level ground, (2) that the wheel not in use during installation is supported to prevent unsafe movement of the motorcycle, (3) and that adequately secured stabilizer straps are used to support the motorcycle while it is elevated. NEVER work on the motorcycle until you have checked to ensure that the motorcycle will be stable during installation.
- If a preload adjustment is necessary for your application, use the supplied FOX Preload Spanner (398-01-289 or 398-01-323) to avoid damaging your preload adjuster. If you cannot reach your optimal ride height within the kit's available preload adjustment, you will need to go up in spring rate to one that fits the application.
- The springs are coated with a corrosion-resistant oil that requires eye protection and gloves for safe handling. Wear safety glasses and rubber gloves when disassembling and reassembling fork legs as they are under spring tension and contain oil. Avoid contact with eyes and skin. Do not ingest and avoid repeated inhalation of vapor.
- The top cap may come out with more force than you expect, which can cause bodily injury. Keep your body and face, along with all other objects, out of the path of the top cap as it is removed.
- Take care when clamping the fork into a fork vise or bench vise, as damage can occur.
- The rebound cartridge assembly will be installed into the right (throttle side) fork leg. The compression cartridge assembly will be installed into the left (clutch side) fork leg.

## ⚠ WARNING

# INSTALLATION GUIDELINES

## TOOLS REQUIRED

- Gloves
- Safety glasses
- Vehicle manufacturer's workshop manual for torque specifications
- Assorted sockets, ratchets, hex bits, and Torx® bits for fork removal and installation
- Torque wrench
- Bench vise
- 12 mm long hex bit
- 14, 15, and 45 mm wrenches
- Cartridge shaft holding tool (included in kit: 398-01-292)
- Cartridge shaft bleed tool (included in kit: 398-01-293)
- Preload adjust spanner (included in kit: 398-01-289 or 398-01-323)
- Oil height / air gap tool
- 2 quart FOX 5WT PTFE infused suspension fluid (included in kit: 025-03-023)

Required tools and supplies may change over time. Visit [ridefox.com](http://ridefox.com) or contact a representative for the most up-to-date details.

## KIT CONTENTS

**IMPORTANT:** Check to make sure all kit items are present prior to starting installation procedure.

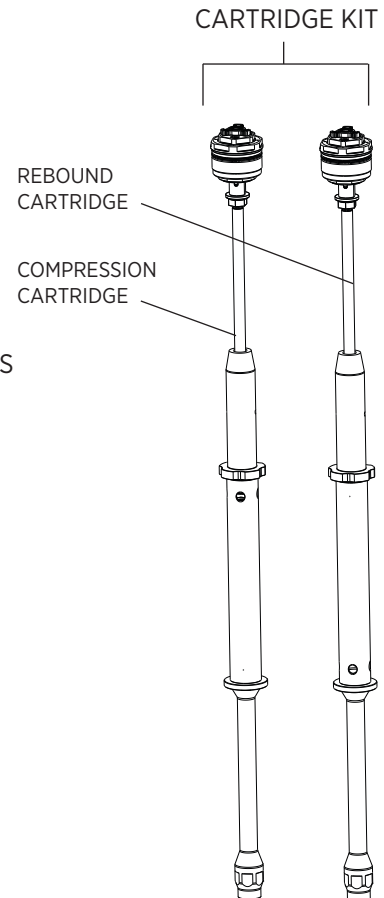
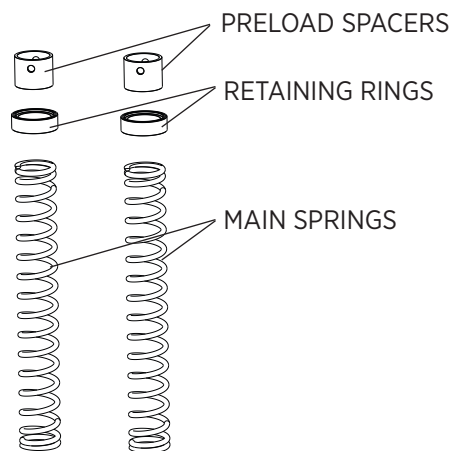
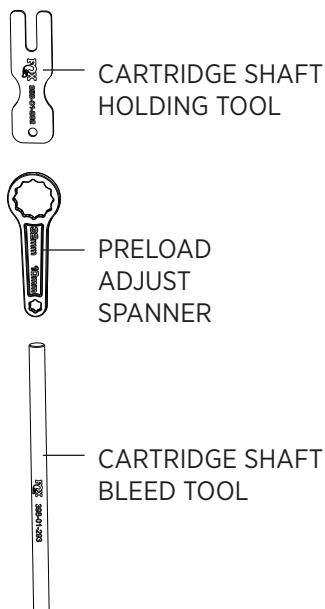

# FORK LEG REMOVAL

## GRIP ST CARTRIDGE KIT INSTALLATION

**⚠ WARNING:** Refer to pages 1-4 in this manual for Safety and Installation Instructions.

**NOTICE:** The rebound cartridge assembly will be installed into the right (throttle side) fork leg. The compression cartridge assembly will be installed into the left (clutch side) fork leg.

**NOTICE:** All fork disassembly instructions are repeated for the second fork leg. However, it is recommended to complete the “Fork Leg Disassembly” and “Fork Leg Reassembly” sections for one fork leg before working on the second fork leg.

1. Use a motorcycle floor jack for the installation of fork components, and make certain that the raised motorcycle is securely attached to the lift to prevent the motorcycle from slipping, falling, or moving during the installation process. This will remove the load on the mounting hardware.
2. Prior to removal of the fork legs, note the fork leg height relative to the triple clamps (Fig. 1). Note the left (clutch side) and right (throttle side) leg separately so the cartridges are installed into the correct side.
3. Remove the front wheel, brake caliper, fender, any fairings, and the fork legs from your motorcycle according to your vehicle manufacturer’s workshop manual and secure them in a fork clamp.

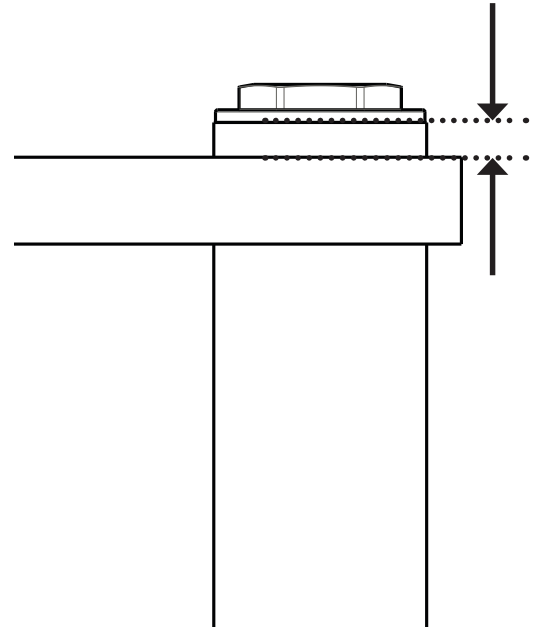

Fig. 1: Note the fork position relative to the triple clamp.

# FORK DISASSEMBLY

**⚠ WARNING:** The springs are coated with a corrosion-resistant oil that requires eye protection and gloves for safe handling. Wear safety glasses and rubber gloves when disassembling and reassembling fork legs as they are under spring tension and contain oil. Avoid contact with eyes and skin. Do not ingest and avoid repeated inhalation of vapor.

1. Clamp the upper tube, then loosen the top cap (Fig. 2A) with appropriately sized tool.

**NOTICE:** Use care when clamping not to damage the upper tube.

2. Keep downward force on the top cap and tool while unthreading the cap. Carefully remove the top cap, keeping your body and other objects out of the path of the cap (Fig. 2).

**⚠ WARNING:** The top cap may come out with more force than you expect, which can cause bodily injury. Keep your body and face, along with all other objects, out of the path of the top cap as it is removed.

3. Remove the stock preload spacer (Fig. 2B), the stock spring washer (Fig. 2C), and the stock spring (Fig. 2D).

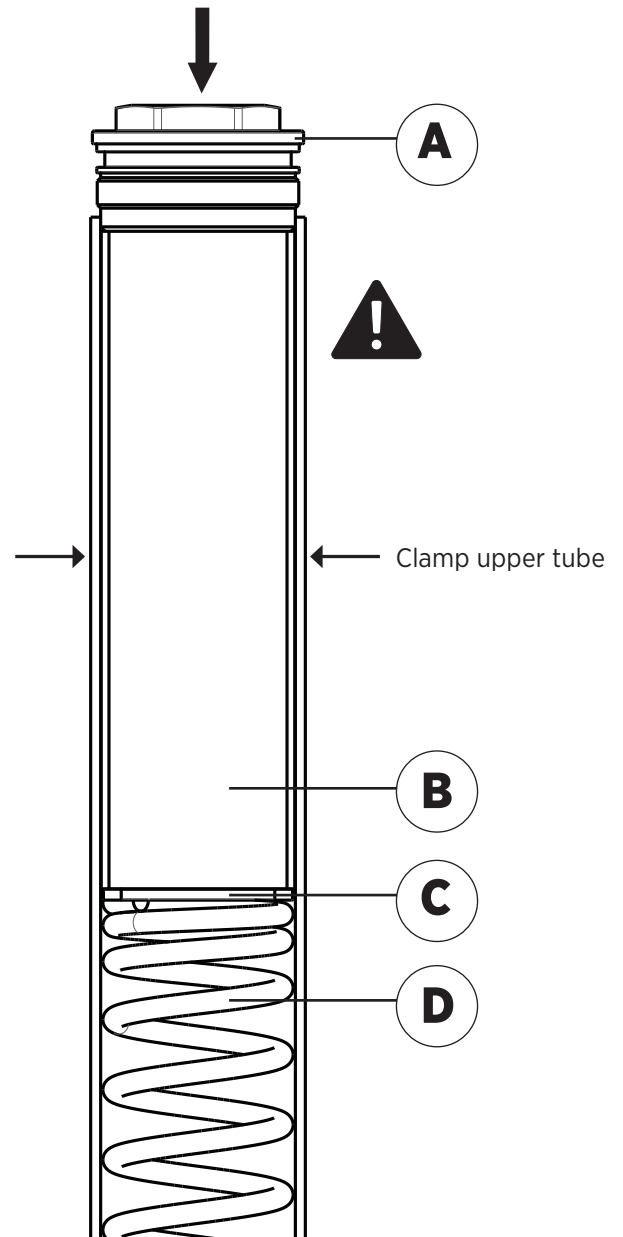

Fig. 2: Carefully remove the top cap.

4. Drain the oil into a clean container by holding the fork upside down and cycling the fork several times from full extension to full compression.
5. Clamp the lower tube in a vise with access to the retaining screw (Fig. 3 and Fig. 4).  
**NOTICE:** Use care when clamping not to damage the lower tube.
6. Remove the damping post retaining screw (Fig. 3A). Apply pressure to the damping post with the main spring to keep the post from rotating inside the leg as you remove the retaining screw.
7. Compress the fork to hold the bottom-out cup (Fig. 4A) in place. Turn the fork upside down to remove the damping post (Fig. 4B) and negative/top out spring (Fig. 4C).
8. Go to the next section to reassemble this fork leg before moving on to the second fork leg. Then, repeat the disassembly and reassembly for the other fork leg.

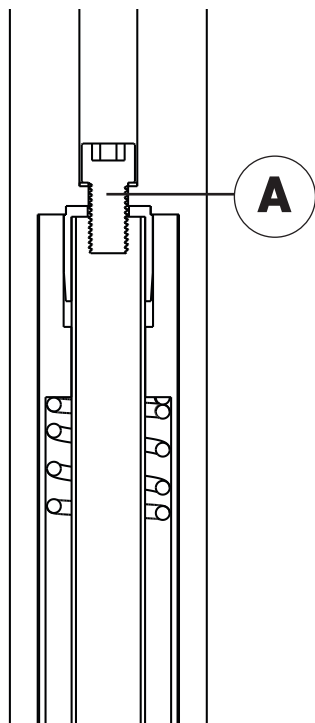

Fig. 3: Remove the damping post retaining screw (A).

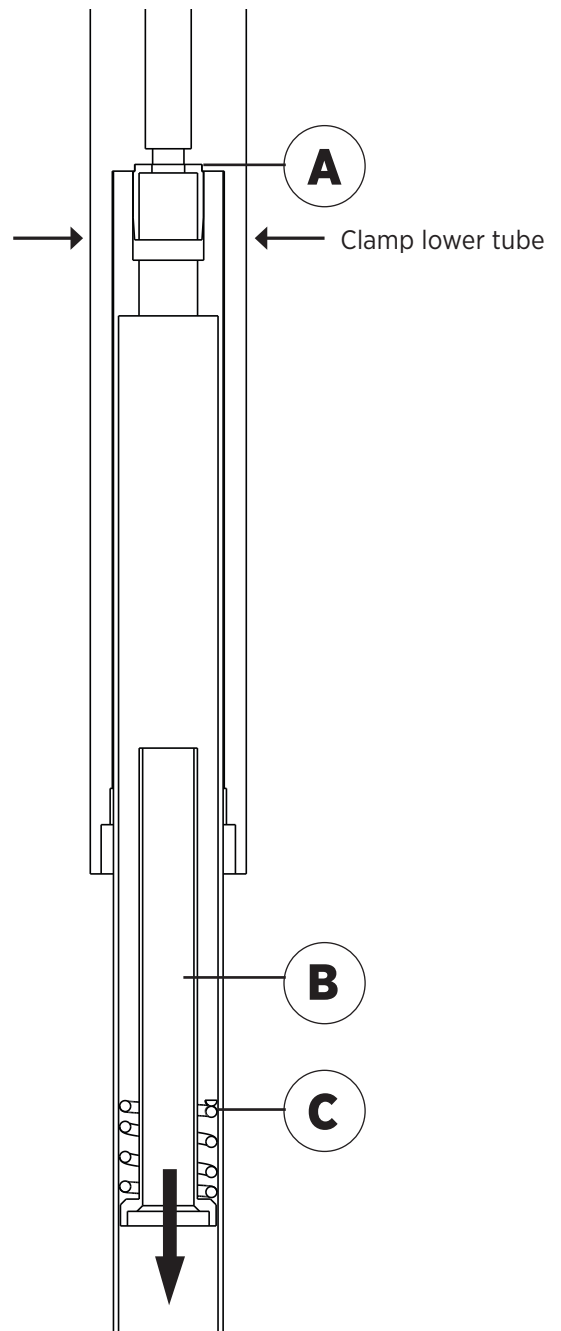

Fig. 4: Compress fork to retain bottom-out cup; remove the damper tube (A) and negative/top out spring (B).

# FORK REASSEMBLY

## REASSEMBLE THE FORK LEG

**NOTICE:** All fork reassembly instructions are repeated for the second fork leg.

**IMPORTANT:** Do not mix parts. Make sure to work on one side of the fork leg at a time.

1. Ensure the bottom out cup is properly seated in the lower lug (Fig. 5A).

2. Install the negative spring into the fork leg.

**NOTICE:** See the Negative Spring Chart below to determine if you should re-purpose your existing negative spring or use the supplied negative spring.

3. Remove the top cap assembly from the shaft (Fig. 6A). Use a 14 mm wrench, if necessary. Ensure the cinch nut (Fig. 6B) and spring guide (Fig. 6C) and are installed on the cartridge assembly.

4. Ensure the cinch nut is seated on the shaft shoulder (Fig. 7).

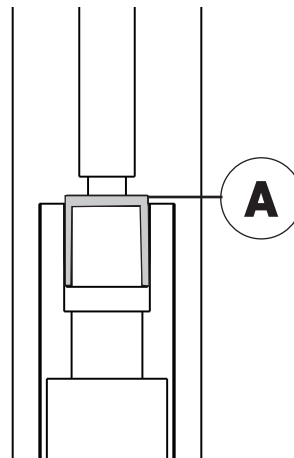

Fig. 5: Bottom out cup seated in lower lug.

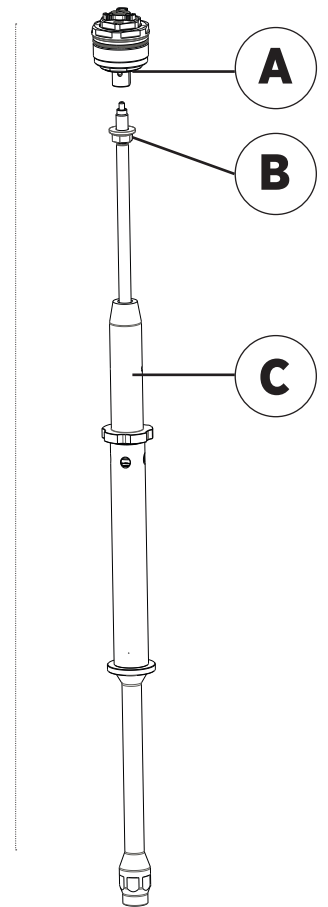

Fig. 6: Top cap removal and cartridge assembly ready to install in fork leg.

### NEGATIVE SPRING CHART

APPLICABLE KIT PART NUMBER	Model Year	Negative Spring
890-27-010	2014-2016	Use FOX Supplied Spring
	2017+	Use Stock Negative Spring
890-27-014	All	Use Stock Negative Spring
890-27-016	All	Use Stock Negative Spring

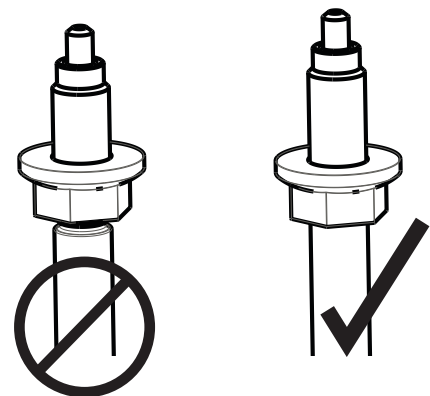

Fig. 7: Cinch nut seated on shaft shoulder.

5. Insert the cartridge assembly: the rebound cartridge installs into the right fork leg (throttle side), and the compression cartridge installs into the left fork leg (clutch side). Confirm that the installation matches the diagram (Fig. 8 and Fig. 9).
6. Install the fork screw (Fig. 8A) and washer (Fig. 8B), according to the manufacturer's workshop manual. If the cartridge body spins and torque cannot be achieved, install the main spring and apply pressure to resist this rotation until the proper torque is achieved.

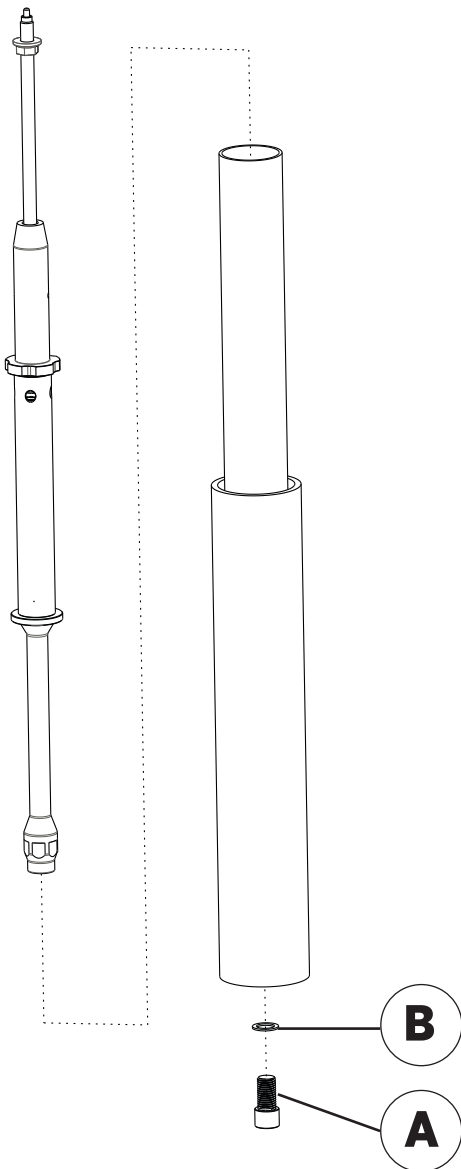

Fig. 8: Install the cartridge (compression leg shown)

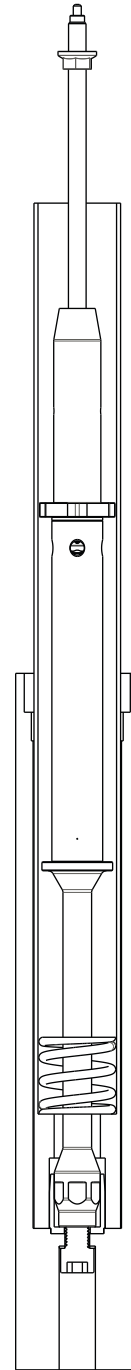

Fig. 9: Install the cartridge (compression leg shown).

- Carefully secure the fork upright by clamping the lower tube. Confirm that the upper tube is in the lowest position (fully compressed).

**NOTICE:** Use care when clamping not to damage the fork leg.

- Loosely thread the cartridge shaft bleed tool (Fig. 10A) onto the shaft. Make sure to thread a minimum of 3 turns.

- Start by adding 500mL of the FOX 5WT PTFE infused suspension fluid, included with kit.

**NOTICE:** Springs, spring retainer, and preload spacer should not be installed at this time. It will be installed in a later step.

- Cycle the upper tube from full compression to full extension 5 times, which will allow oil to fill between the upper and lower tubes.
- Bleed air from the cartridge by cycling the shaft to full compression and full extension 10 times (Fig. 10).

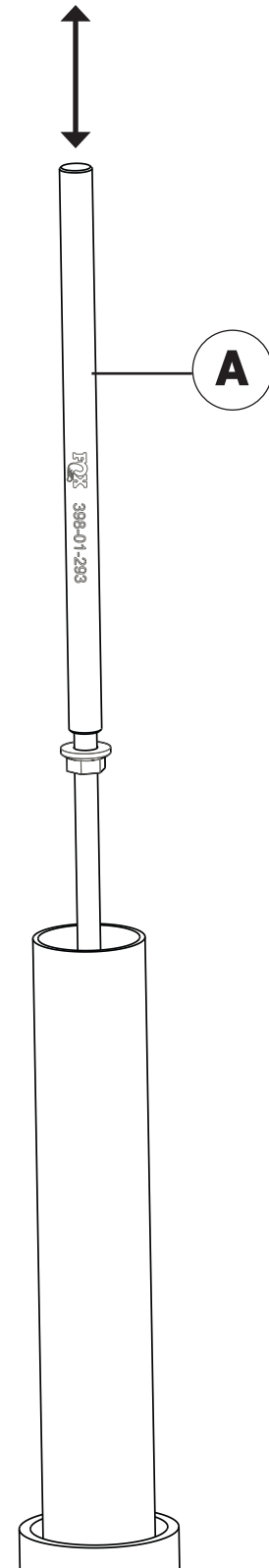

Fig. 10: Cartridge shaft bleed tool installed (A); bleed air out of cartridge by cycling the shaft.

- Set the air gap to the specified level shown in the Air Gap Height Chart below; ensure that you match the information recommended for your specific application.

**NOTICE:** Set the upper tube to the lowest position when measuring the air gap. Additionally, set the cartridge shaft to the lowest position when measuring the air gap. If the air gap does not match what is specified by the Air Gap Height Chart below, add or remove oil until the proper air gap is achieved.

- Install the main spring, the spring retainer, and preload spacer in the order shown (Fig. 11). Make sure the groove on the spring retainer faces the preload spacer (Fig. 11 arrow).

AIR GAP HEIGHT CHART	
APPLICABLE KIT PART NUMBER	Air Gap (mm)
890-27-010	125
890-27-014	128
890-27-016	128

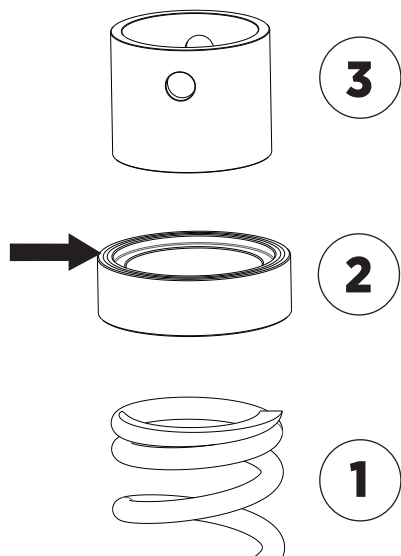

Fig. 11: Install spring and spring hardware in numbered order above; note groove orientation on the spring retainer (arrow).

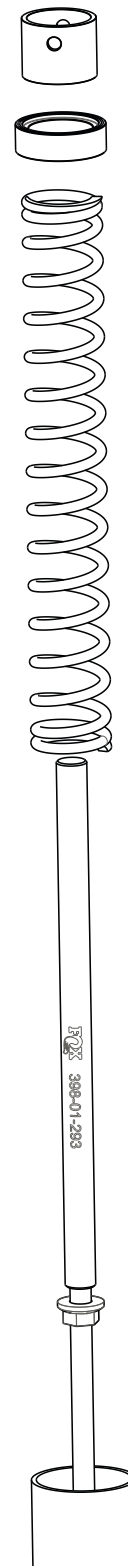

Fig. 12: Install spring and spring hardware .

14. Compress the spring until the cartridge shaft holding tool (Fig. 13B) can be inserted between the preload spacer and the cinch nut (Fig. 13).
15. Unthread and remove the cartridge shaft bleed tool (Fig. 13A) from the shaft (Fig. 14).

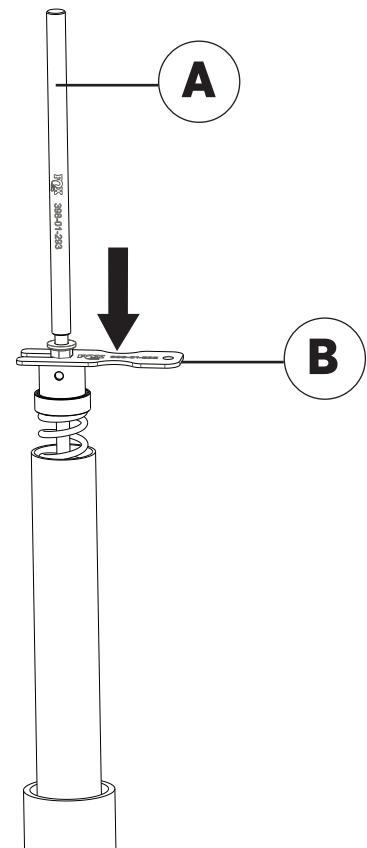

Fig. 13: Compress the spring downward (arrow) and insert the cartridge shaft holding tool (B).

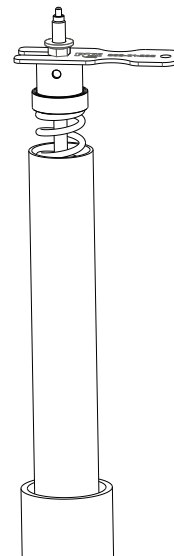

Fig. 14: Remove the cartridge shaft bleed tool.

16. Thread the top cap assembly onto the shaft (Fig. 15). Make sure the preload adjuster is at the minimum setting. Ensure that the top cap assembly sits flush on the shaft; there will be a gap between the top cap assembly and the cinch nut.

17. Use a 14 mm wrench to hold the top cap, and a 15 mm wrench to tighten the cinch nut against the top cap. Torque the cinch nut to 15 ft-lb.

18. Carefully remove the cartridge shaft holding tool (Fig. 15)

**⚠️ WARNING:** Pinch Hazard. The cartridge shaft holding tool will be under spring force, so be extremely careful as you remove it from between the preload spacer and the cinch nut. Keep hands, fingers and other body parts away from the preload spacer and top cap when removing the cartridge shaft holding tool.

19. Check that the preload spacer is correctly seated on the top cap (Fig. 16; arrow), and that the spring, spring retainer, preload spacer, and top cap assembly are all aligned properly.

20. Compress the top cap and thread the top cap onto the upper tube (Fig. 16). Use a 45 mm wrench to torque the top cap to the manufacturer's specifications.

21. Set the fork preload using the Fork Setup charts on page 15.

22. Repeat the "Fork Disassembly" and "Fork Reassembly" sections for the other fork leg.

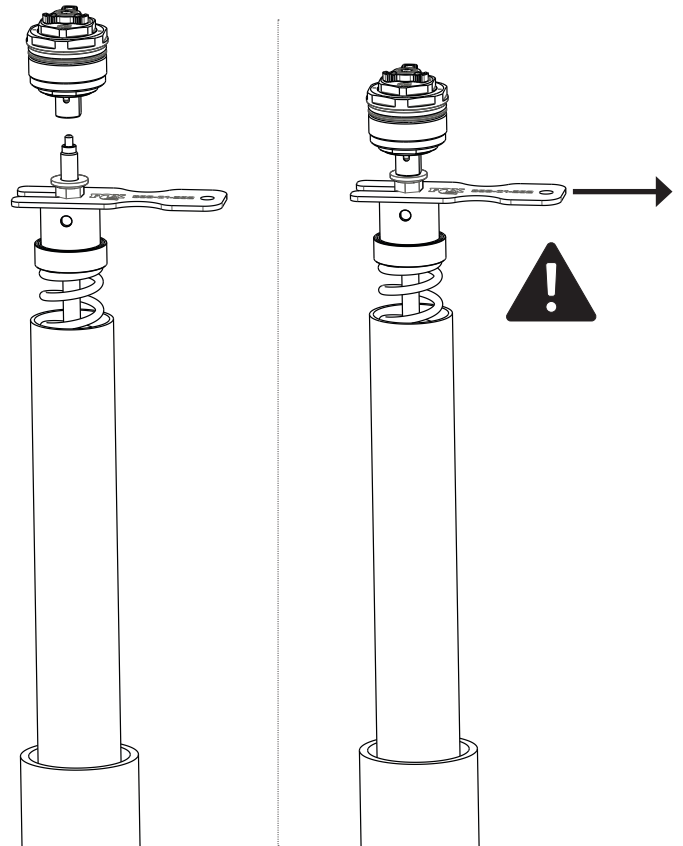

Fig. 15: Thread the top cap assembly onto the shaft; then remove the shaft hold tool

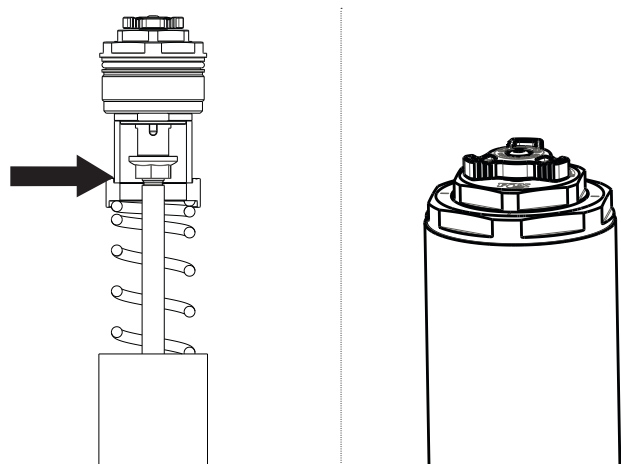

Fig. 16: Preload spacer seated on top cap (left; see arrow). Compress the top cap to thread and torque it onto the upper tube (right).

# FORK LEG INSTALLATION

---

## FORK LEG INSTALLATION

1. Use the manufacturer's workshop manual to reinstall the fork leg and other removed components on the vehicle. Reference the height you measured when removing the fork ("Fork Leg Removal" section, Step 2, Fig. 1) to set the same distance between the fork leg height and the triple clamp. Refer to the manufacturer's workshop manual when setting the fork height in the triple clamps.

# FORK SET UP

## GRIP ST CARTRIDGE KITS

### ADJUSTING SPRING PRELOAD

FOX GRIP ST Cartridge kits are equipped with spring preload adjusters that have 24 preload positions. Use the preload spanner (Fig. 17A) to adjust spring preload. To adjust the spring preload, rotate the preload adjuster clockwise to increase spring preload and counter clockwise to decrease spring preload. Keep track of the spring preload by counting clicks.

Use the charts on this page to find the preload setting recommended for your rider(s) weight, including gear. If you cannot reach your optimal ride height within the fork's available preload adjustment, you will need to go up in spring rate to one that fits the application. If you have any questions call the FOX motorcycle shock service center at 831.740.4619.

**! WARNING:** Modifying preload spacer length will void the warranty and could result in **SERIOUS INJURY** and/or **DEATH**.

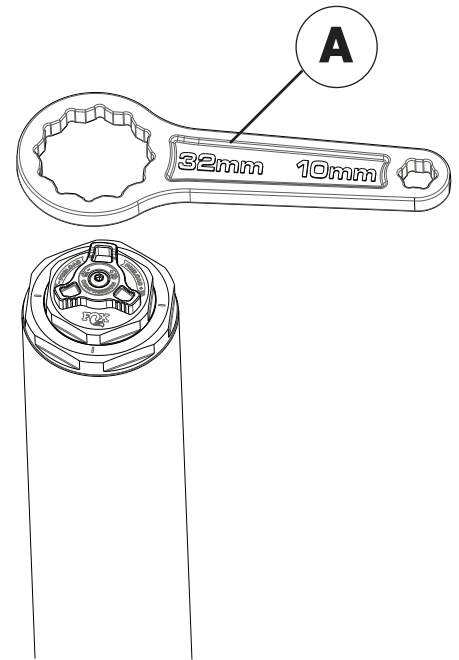

Fig. 17: Spring preload can be adjusted with supplied preload adjust spanner (A); compression leg shown.

TOURING STANDARD SPRING PRELOAD CHART	
RIDER WEIGHT WITH GEAR (LB)	Number of Preload Clicks*
<110	0
140	4
170	8
200	12
230	16
260	20
>290	24

DYNA STANDARD SPRING PRELOAD CHART	
RIDER WEIGHT WITH GEAR (LB)	Number of Preload Clicks*
<120	0
140	4
160	8
185	12
210	16
230	20
>255	24

SOFTAIL STANDARD SPRING PRELOAD CHART	
RIDER WEIGHT WITH GEAR (LB)	Number of Preload Clicks*
<120	0
140	4
160	8
190	12
210	16
230	20
>255	24

\* Preload clicks are counted from full counter-clockwise

# FORK SET UP

## QS3 COMPRESSION ADJUST

The Quick Switch Compression adjust feature gives you the ability to easily adjust the fork's compression damping with three easy clicks. Adjustments are made by turning the adjuster knob on the top cap (Fig. 18).

The factory setting is Position 2 (Fig. 18). The performance of the fork at this setting is a good balance between comfort and control. For firmer compression, turn the knob clockwise. For softer compression, turn the knob counter-clockwise (Fig. 19).

Adjusting the compression affects how quickly the fork compresses when bumps or corners are encountered. The optimum compression setting usually requires the least amount of damping possible without bottoming out the fork.

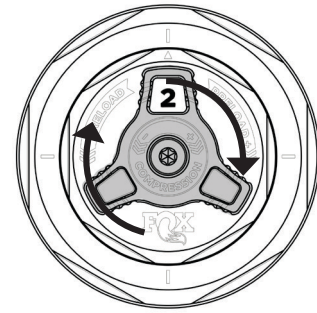
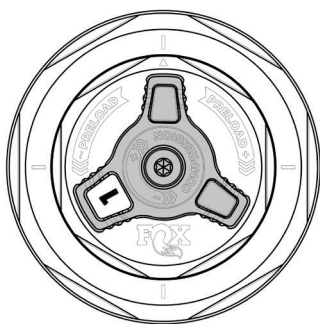
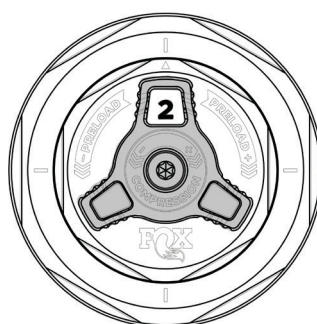

Fig. 18: QS3 compression adjuster shown in factory setting Position 2.

TUNING COMPRESSION DAMPING	
SYMPTOM	REMEDY
Rigid, harsh ride	Turn counter-clockwise
Excessive weight transfer	Turn clockwise
Bottoms out often	Turn clockwise
Suspension not using full travel	Turn counter-clockwise



Position 1 (Soft)



Position 2 (Medium)

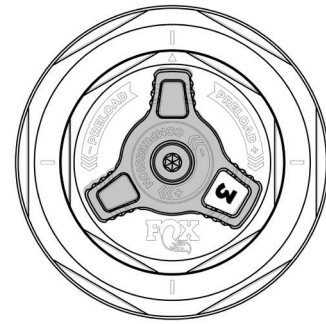

Position 3 (Firm)

Fig. 19: QS3 compression damping adjustments.

# FORK SET UP

## QSR REBOUND ADJUST

The Quick Switch Rebound adjust feature gives you the ability to easily adjust the fork's rebound damping with three easy clicks (Fig. 20). The factory setting is Position 2 (Fig. 20). The performance of the fork at this setting is a good all-around setting. For slower rebound, turn the knob clockwise. For faster rebound turn the knob counter-clockwise (Fig. 21).

Adjusting the rebound affects how quickly the wheel rebounds when traveling through a series of bumps and also determines how quickly the front end responds in corners. The optimum rebound setting usually requires the least amount of damping possible without the motorcycle feeling like it is bouncing off of every bump.

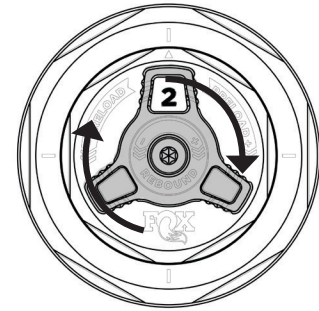
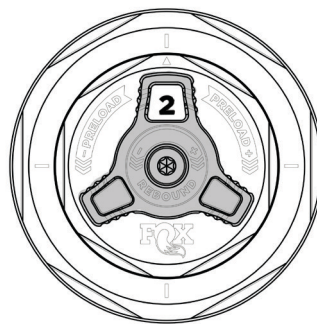

Fig. 20: QSR rebound adjuster, shown in factory setting Position 2.

TUNING REBOUND DAMPING	
SYMPTOM	REMEDY
Harsh over bumps	Turn counter-clockwise
Excessive weight transfer	Turn clockwise
Wallows in corners	Turn clockwise



Position 1 (Fast)



Position 2 (Medium)

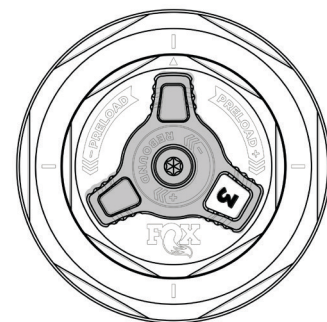

Position 3 (Slow)

Fig. 21: QSR rebound damping adjustments.

# MAINTENANCE

---

SEE OIL CHANGE INTERVAL LISTED IN VEHICLE SERVICE MANUAL.

PROPER INSPECTION AND MAINTENANCE IS ESSENTIAL TO MAINTAIN THE PERFORMANCE AND RELIABILITY OF YOUR FORK KIT.

It is important to keep the forks clean and free of dirt.

The service interval depends on how frequently and aggressively the motorcycle is ridden. Under normal usage, it is recommended to have the forks completely inspected and serviced annually.

## FOX SERVICE AND UPGRADES

HAVE YOUR FOX SHOCKS SERVICED OR UPGRADED BY FOX TECHNICIANS. CALL OUR MOTORCYCLE SERVICE CENTER AT 831.740.4619 TO GO OVER THE SERVICE AND UPGRADE OPTIONS AVAILABLE FOR YOUR SHOCKS. ONCE YOU'VE SETUP YOUR SERVICE AND/OR UPGRADES, YOU WILL RECEIVE A RETURN AUTHORIZATION NUMBER AND SHIPPING INSTRUCTIONS.

## COMPLETE SERVICES

Normal use: once per season

Racing or extreme use: may require more frequent service

## SERVICE MENUS AND PRICING

visit [ridefox.com/service](http://ridefox.com/service)



**WARNING: Cancer and  
Reproductive Harm –**  
[www.P65Warnings.ca.gov](http://www.P65Warnings.ca.gov)

# WARRANTY INFORMATION

## FOX LIMITED WARRANTY

FOX Factory, Inc., a Georgia corporation having an office at 2055 Sugarloaf Circle Suite 300. Duluth, GA 30097 (“FOX”), makes the following LIMITED WARRANTY with respect to its suspension products:  
LIMITED ONE (1) YEAR WARRANTY ON SUSPENSION PRODUCTS.

Subject to the limitations, terms and conditions hereof, FOX warrants, to the original retail owner of each new FOX suspension product, that the FOX suspension product, when new, is free from defects in materials and workmanship. Unless otherwise required by law, this warranty expires one (1) year from the date of the original FOX suspension product retail purchase from an authorized FOX dealer or from a FOX authorized Original Equipment Manufacturer where FOX suspension is included as original equipment on a purchased vehicle. If law requires a warranty duration of greater than one (1) year, then, subject to the other provisions hereof, this warranty will expire at the end of the minimum warranty period required by such law.

## TERMS OF WARRANTY

This warranty is conditioned on the FOX suspension product being operated under normal conditions and properly maintained as specified by FOX. This warranty is only applicable to FOX suspensions purchased new from an authorized FOX source and is made only to the original retail owner of the new FOX suspension product and is not transferable to subsequent owners. This warranty is void if the FOX suspension product is subjected to abuse, neglect, improper or unauthorized repair, improper or unauthorized service or maintenance, alteration, modification, accident or other abnormal, excessive, or improper use.

Should it be determined by FOX in its sole and final discretion, that a FOX suspension product is covered by this warranty, it will be repaired or replaced, by a comparable model, at FOX’s sole option, which will be conclusive and binding. THIS IS THE EXCLUSIVE REMEDY UNDER THIS WARRANTY. ANY AND ALL OTHER REMEDIES AND DAMAGES THAT MAY OTHERWISE BE APPLICABLE ARE EXCLUDED, INCLUDING, BUT NOT LIMITED TO, INCIDENTAL OR CONSEQUENTIAL DAMAGES OR PUNITIVE DAMAGES.

This limited warranty does not apply to normal wear and tear, malfunctions or failures that result from abuse, improper assembly, neglect, alteration, improper maintenance, crash, misuse or collision. This limited warranty gives the consumer specific legal rights. The consumer may also have other legal rights which vary from state to state or country to country. Some states and countries do not allow the exclusion or limitation of incidental or consequential damages or warranties, and if dictated by law the above limitations or exclusions may not apply to you. If it is determined by a court of competent jurisdiction that a certain provision of this limited warranty does not apply, such determination shall not affect any other provision of this limited warranty and all other provisions shall remain in full effect.

THIS IS THE ONLY WARRANTY MADE BY FOX ON ITS SUSPENSION PRODUCTS AND COMPONENTS, AND THERE ARE NO WARRANTIES WHICH EXTEND BEYOND THE DESCRIPTION HEREIN. ANY WARRANTIES THAT MAY OTHERWISE BE IMPLIED BY LAW INCLUDING, BUT NOT LIMITED TO, ANY IMPLIED WARRANTY OF MERCHANTABILITY OR FITNESS FOR A PARTICULAR PURPOSE ARE EXCLUDED.

# CONTACT

---

## FOX RACING SHOX

A DIVISION OF FOX FACTORY INC.

6634 HWY 53. Braselton, GA 30517 USA

1.800.FOX.SHOX (1.800.369.7469)

[servicemn@ridefox.com](mailto:servicemn@ridefox.com)

