



**INSTALLATION
INSTRUCTIONS**

SIMPLY SUPERIOR.

**REAR COIL-OVER CONVERSION
2007-2018 JEEP JK WRANGLER
4 DOOR MODELS**

JKS2519

www.jksmfg.com | jks@ridefox.com | 517-278-1226

RV. 051920

GETTING STARTED

Read all warnings, instructions, notes and cautions before you begin the installation.



WHO SHOULD INSTALL THIS?

We recommend that this system be installed by a professional mechanic. The installer will need professional knowledge of special tools required for installation as well as assembly and disassembly procedures.

STAYING SAFE AND LEGAL

- If you fail to drive your lifted and modified vehicle safely it may result in serious injury or death.
- Exercise caution: A lifted vehicle is at greater risk for rollovers or loss of control, especially during abrupt maneuvers.
- Always wear your seat belt, reduce your speed and avoid sharp turns.
- Never operate your vehicle under the influence of drugs or alcohol.
- Consult local and state laws for the legality of your ride height.

BEFORE YOU BEGIN INSTALLATION

- Needed items: OE service manual for your vehicle, safety glasses, and any special tools as indicated in these instructions as well as the following tools: assorted metric and standard wrenches, hammer, hydraulic floor jack and a set of jack stands.
- Ride Height: Measure the initial ride height of your vehicle prior to installation. Final ride height may vary depending on the factory height of your vehicle.
- Tires and rims: Larger tire and rim combinations can increase leverage and cause additional stress to suspension, steering, and related components. When installing larger than OE tires and rims, the following components should be inspected for wear every 2500-5000 miles: ball joints, tie rod ends, wheel bearings, track bar bushings, pitman arm.
- Drive line vibrations: Some vehicles may experience drive line vibration after installation of this suspension system. Possible remedies for this include: tuning angles, replacement of slider on shaft, lengthening or truing of shaft, and/or replacing u-joints.

THANK YOU FOR CHOOSING JKS

TIRE FITMENT

3.5" LIFT
35x12.50 on 16x8 with 4.5" max backspacing

SPECIAL TOOLS REQUIRED

4-½" angle grinder with cut off wheel, flap disc
½" drill bit
Sawzall

INSTALLATION TIME

Approximately 6-8 hours

PRE-INSTALLATION NOTES

- a. Reservoir mounts are not designed to work with factory rear bumper.
- b. This kit is designed as an upgrade to a 2.5"-4" lift system. Additional components are necessary for installation on a stock vehicle.
- c. Requires a minimum of 2" of additional rear bump stop height from factory.
- d. Not compatible with longer 2.5" diameter coil overs. Install product with JKS recommended Fox 2.5" coil overs only. Some 2.0" coilovers may fit, but it is up to the installer to verify fitment, bump travel, etc.
- e. Requires cutting of the factory shock mounts and is not designed to allow the vehicle to go back to stock configuration.

. REAR DISASSEMBLY

- a. Disconnect the track bar at the axle with the vehicle still on the ground using a 21mm socket. Save bolt and nut tab.
- b. Raise and support the vehicle with jack stands positioned in front of the lower suspension arm brackets. Remove the tires.
- c. Remove the parking brake cable bracket (10mm) [1]. Remove the bracket from the cable, this will not be re-used.
- d. Remove the bolts holding the brake lines to the frame (10mm) [2].

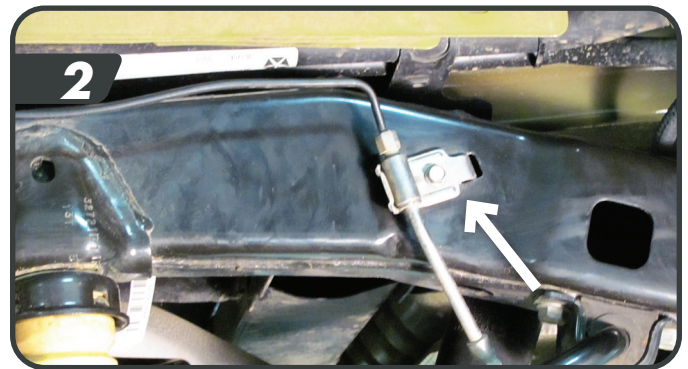
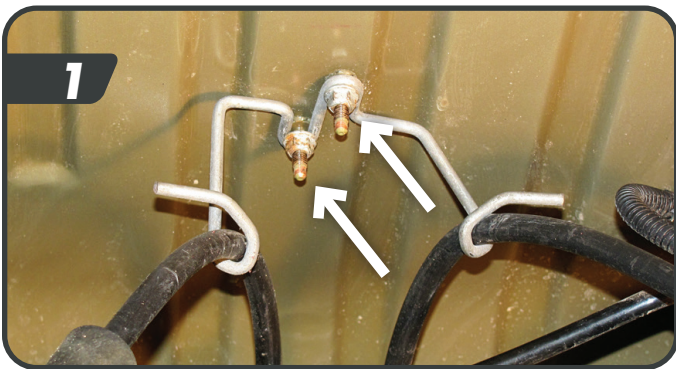

- e. Pry the wheel speed sensor wiring from the bottom of the frame to gain additional slack [3].
- f. Rubicon models: Disconnect the locker wires from the differential.
- g. Support the axle with a jack under the center of the differential and remove the shocks from the frame (16mm) and axle (18mm), save hardware [4].

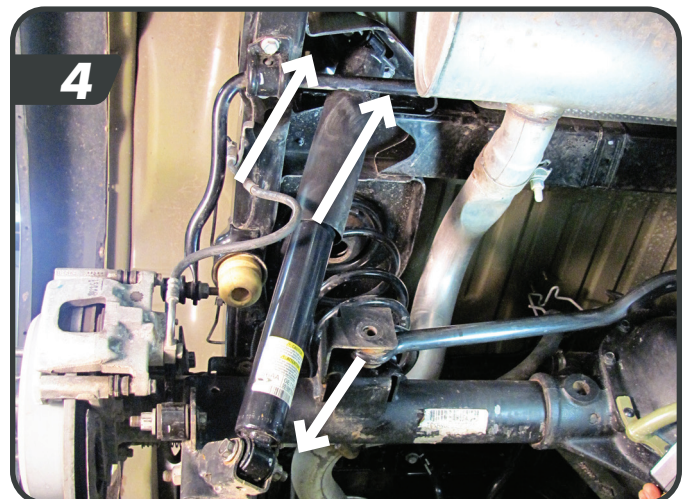
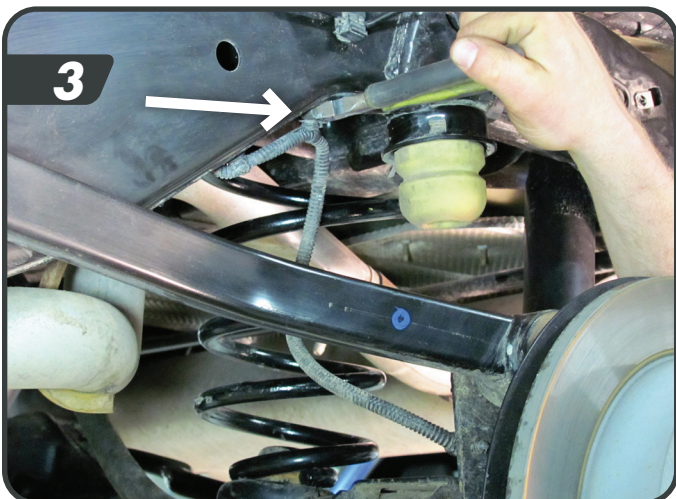

- h. Remove the sway bar links from the axle and save hardware (18mm) [5].
- i. Lower the axle enough to remove the factory springs. Make sure there is adequate slack on all wires.

REAR COILOVER AXLE BRACKET INSTALLATION

Rear axle coilover mounts 03339, 03340 will require bolt pack J157

- a. Using a cutoff wheel or plasma cutter remove the sway bar link and factory shock mount from the axle brackets [7].

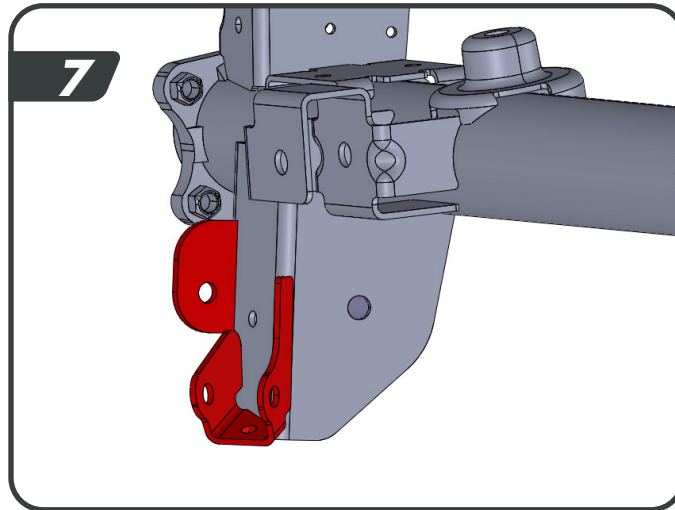

- b. Measure 1.5" down from the center of the lower control arm mounting hole and make a cut perpendicular to the rear face of the mount [8].

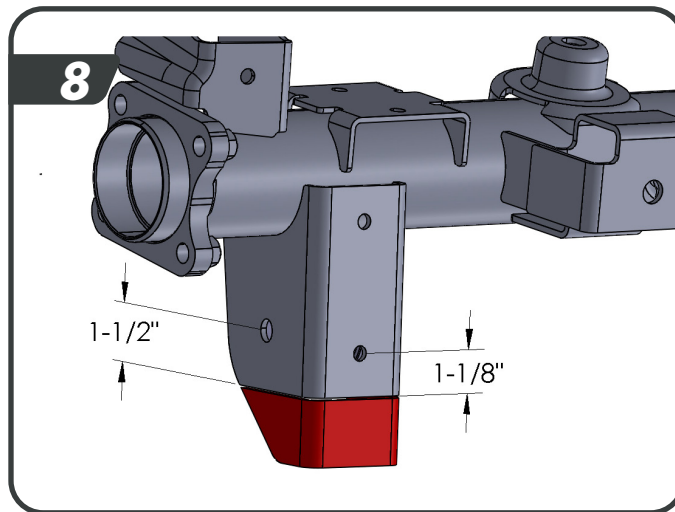

- c. Drill out the 2 factory holes on the rear face of the mount using a 1/2" drill bit [9].



- d. Place the JKS lower coilover mount over the factory bracket. Line the bracket up by temporarily installing the factory control arm bolt and line up the 2 rear holes. Use the provided 7/16" hardware to attach the bracket to the mount. The flange lock nuts can be placed on the bolts using a magnet from the top. Tighten hardware to 70 ft lbs [11].

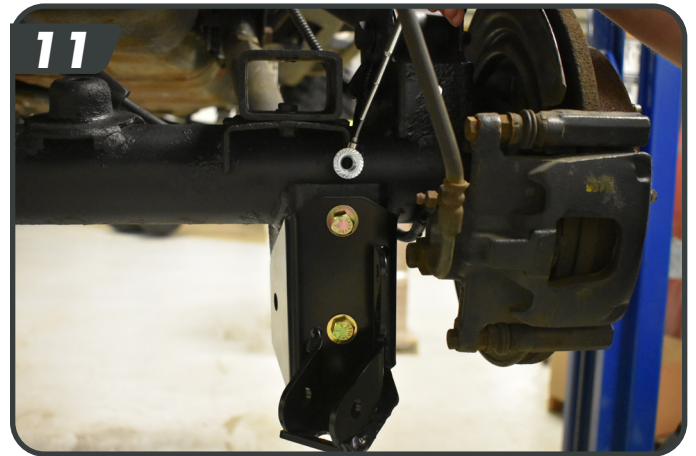

REAR COILOVER FRAME BRACKET INSTALLATION

Rear frame coilover mounts 03337, 03338 will require bolt pack J156 and (4) 1/4" Spacer washers (01499)

- Remove the muffler from the exhaust pipe and both rear hanger mounts from the frame.
- Remove the sway bar from the frame.
- Using a cut off wheel, cut the passenger side exhaust hanger from the frame rail, grind smooth, and paint the frame. Save the rubber mount for re-use.



- d. Measure in 1-5/8" from the frame rail and make a cut line across the factory shock mount to the crossmember. To avoid a lot of grinding, the crossmember side of the shock mount can be cut just past the weld as shown [16].

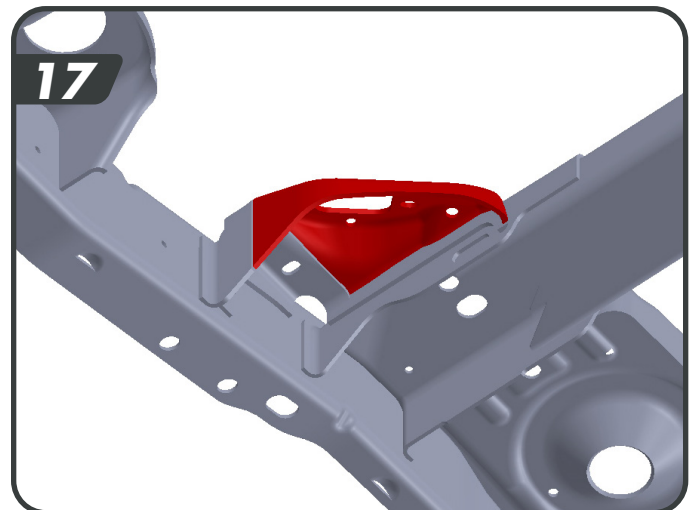
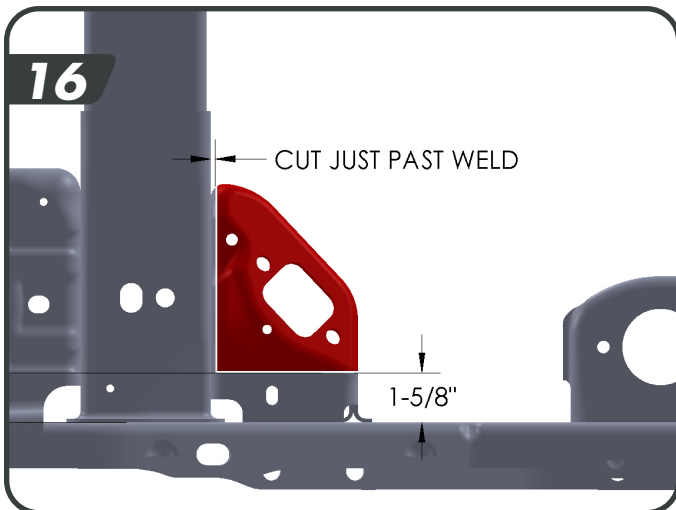

- e. Following the cut marks, remove both upper shock mounts from the frame - sawzall recommended. Clean up any sharp edges with a grinder and paint the frame.
- f. Slide the carriage bolts into the JKS coilover frame mount so they face down to re-mount the sway bar later in the installation [18].
- g. Place the coilover mount on the frame and loosely install the 7/16" x 1" bolt from the bottom up to attach the bracket to the hole in the remaining part of the factory frame shock mount [18].





- h. Install the remaining 7/16" x 1-1/4" hardware in the 4 remaining mounting holes. Install the 1/4" spacer washers at two locations per bracket. One is between the framerrail and bracket, the other is located at the innermost crossmember mount and bracket as shown, leave loose [20].
- i. Install the supplied 10mm hardware through the coilover mount at the factory sway bar mount location.
- j. Once all hardware and spacers have been loosely installed, torque all 7/16" hardware to 50 ft-lbs. Torque 10mm hardware to 33 ft lbs.
- k. Attach the sway bar to the carriage bolts with the provided 3/8" nuts and washers. Torque to 25 ft-lbs.



REAR EXHAUST HANGER MOUNTING

- a. Measure forward on the inside of the frame rail from the factory body mount 3" and make a vertical line. Measure up from the bottom of the frame 1.5" along that line and make a mark. Using the exhaust hanger as a template, line up the lower hole of the bracket at the first mark and make a second mark for the upper hole. Drill these holes at these locations to 9/32" (.281"). Using the supplied 5/16" self tapping bolts, tap the holes but remove for bracket installation once the coilovers have been installed.

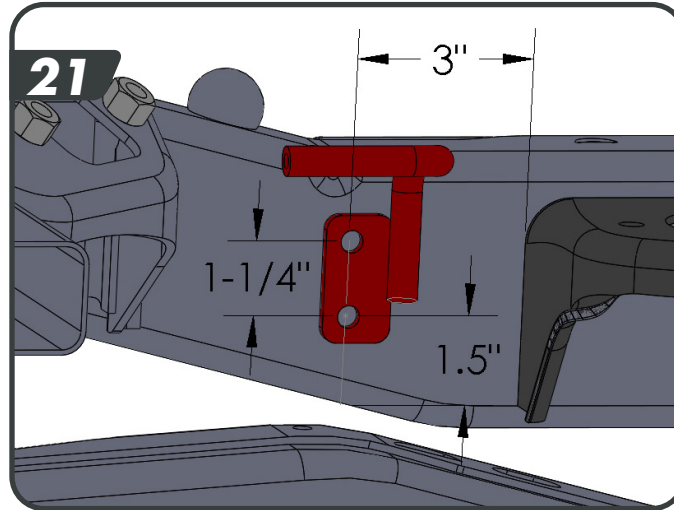

REAR COILOVER INSTALLATION

- a. Carefully slide the reservoir between the frame and body and attach the coilover to the upper mount with the 1/2" x 5-1/2" bolt. The bolt installs from the center of the vehicle towards the outside, the misalignment spacers may need to be compressed slightly to get them into the mount [22].
- b. Raise the axle until the lower eye lines up with the mount and attach the coilover using the 1/2" x 3" bolt. Torque upper and lower hardware to 80 ft-lbs [23].

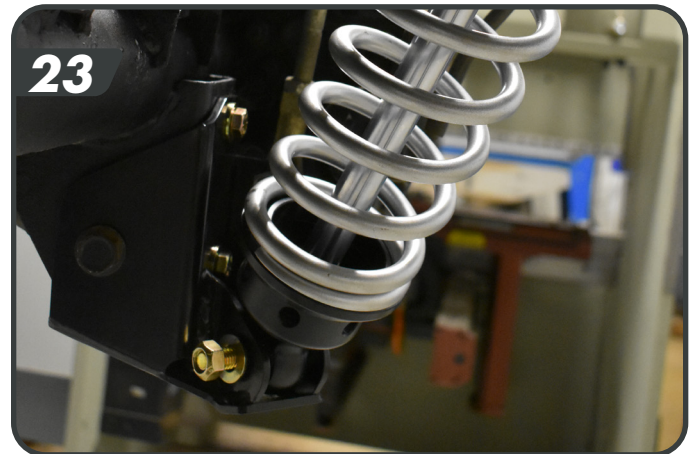
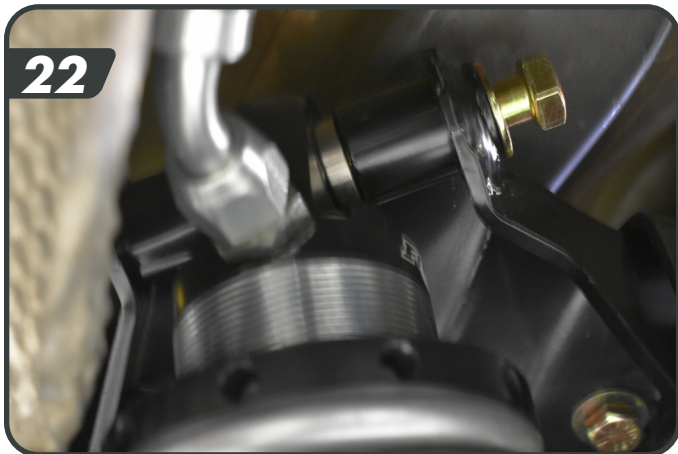

- c. Place the reservoir mount behind the reservoir and the roost shield in front of the reservoir. Attach these to the frame with the supplied 10mm bolts and washers.[24]

Note: Kit is intended to be installed with aftermarket rear bumper and uses the mounting holes where the factory bumper side mounts used to mount to the frame.

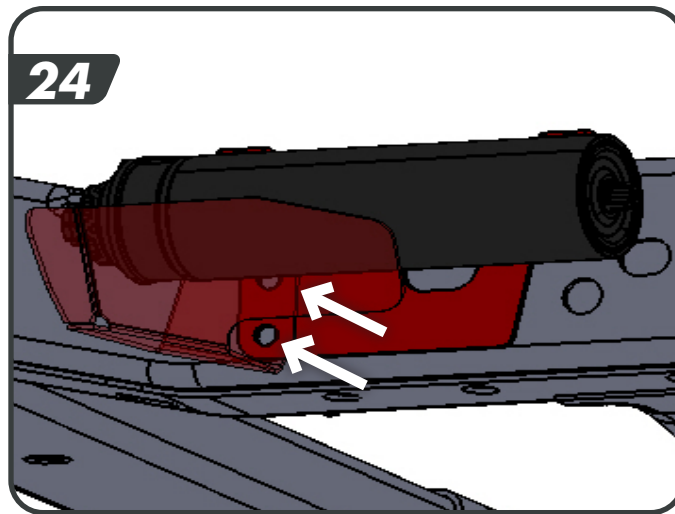

- d. Attach the reservoir to the bracket with the provided hose clamps.

FINAL INSTALLATION STEPS

- a. Re-install the sway bar links to the sway bar and upper hole in the axle bracket using factory hardware.
- b. Re-install the muffler to the exhaust pipe and driver side hanger. Install the supplied passenger side exhaust hanger to the muffler and frame using the provided 5/16" self tapping bolts and factory rubber isolator
- c. Re-install brake lines to frame, ensure there is adequate slack. Re-install only the lower clip for the ABS wire.
- d. Rubicon models: Reattach the locker wire harness to the differential.
- e. Mount the tires and lower the vehicle to the ground.
- f. Reattach the track bar to the axle/frame. Torque the track bar bolts to 110 ft-lbs.
- g. Check all hardware torque after 500 miles.

JKS2519 KIT COMPONENTS

JKS2519 COILOVER MOUNT BOX KIT

Part No.	Qty	Description	Part No.	Qty	Description
03337		Coilover Frame Mount - Drv	J156	1	Bolt Pack Upper Mount Hardware
03338		Coilover Frame Mount - Pass		2	1/2"-13 x 5-1/2" bolt
03339		Rear Axle Coil-over Mount - Drv		2	1/2"-13 prevailing torque nut
03340		Rear Axle Coil-over Mount - Pass		4	1/2" SAE washer
03381		Coilover Reservoir Mount - Drv		4	3/8"-16 x 1" carriage bolt
03382		Coilover Reservoir Mount - Pass		4	3/8"-16 prevailing torque nut
03383		Coilover Reservoir Roost Shield - Drv		4	3/8" SAE washer
03384		Coilover Reservoir Roost Shield - Pass		2	7/16"-14 x 1" bolt
03385		Exhaust Hanger		8	7/16"-14 x 1-1/4" bolt
01499		1/4" Spacer		10	7/16"-14 prevailing torque nut
				24	7/16" SAE washer
				8	10mm-1.50 x 30 mm bolt
				8	10mm flat washer
				2	5/16"-18 x 3/4" self tapping bolt
				1	5/16"-18 x 3/4" Bolt
				3	5/16" SAE Flat Washer
			J157	1	Bolt Pack Lower Mount Hardware
				2	1/2"-13 x 3" bolt
				2	1/2" prevailing torque nut
				4	1/2" SAE flat washer
				4	7/16"-14 x 1" bolt
				4	7/16"-14 serrated flange nut
				4	7/16" SAE flat washer